

AN1066 - Installing an I/O board

I/O boards can be used for any number of applications in conjunction with Net2 Triggers and Actions. For further information on Triggers and Actions see: [AN1067 - Using triggers and actions](http://paxton.info/507). < <http://paxton.info/507> >

Installing the hardware

There are 4 inputs and 4 outputs on the I/O board. The input pair must be wired across clean contacts (switch or relay). The outputs are 13A / 240V AC voltage-free relays and can be used for any purpose.

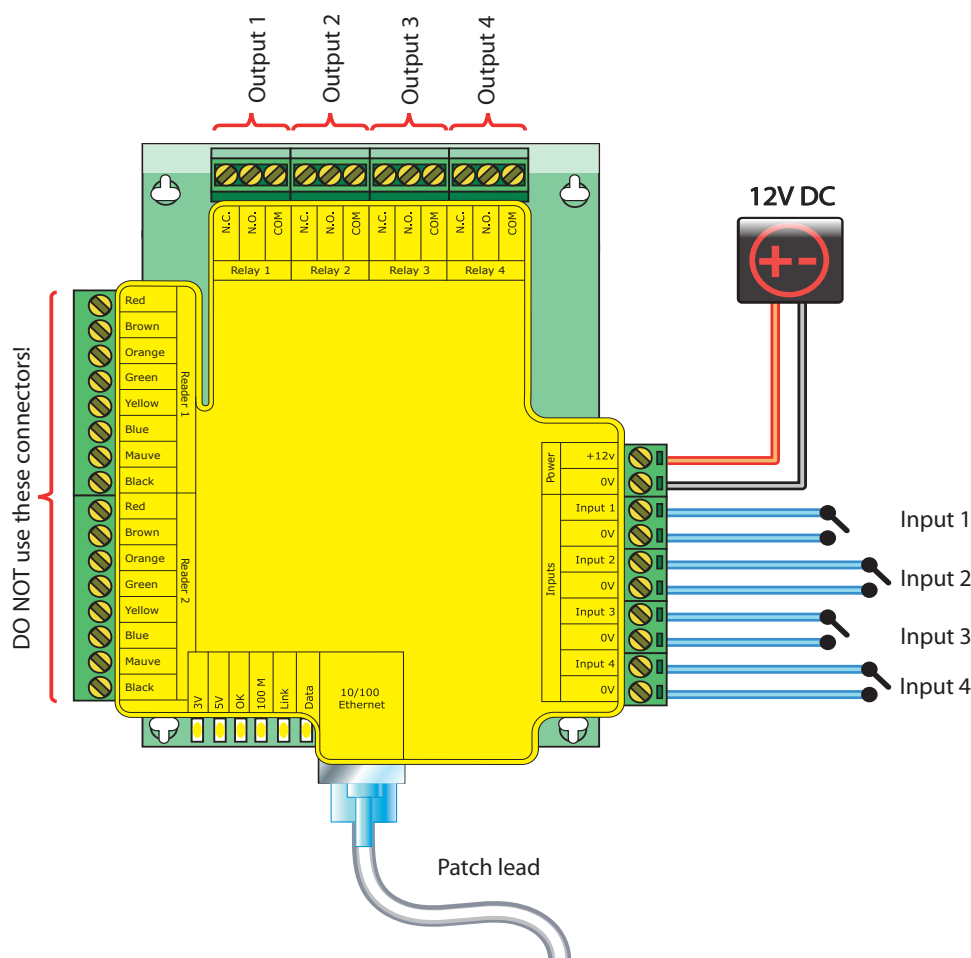

Once the I/O board has been installed, ensure that the network connection is in place and connected to the LAN before the unit is powered up.

Full details on how to detect the I/O board can be found with the product: [ins-30019 - Net2 I/O board](http://paxton.info/1596). < <http://paxton.info/1596> >

Important

For the I/O boards to operate correctly there needs to be permanent communication between the Net2 Server and the boards.

The IP address should be reserved by the IT administrator and fixed in the server.

Software configuration

If you detect the MAC address but the device now shows 'Not Responding', check the IP address to make sure it is still in range with the PC or network. If it is not, you should either change the PC's IP address or the Ethernet interface's IP address so they are both again in the same range. Our Technical team can talk you through this if you need help.

If the MAC address does not appear when you click 'Detect' then you will need to check that the following ports are open:-

6480	TCP
6481	UDP
6482	UDP
6483	UDP

Detect - This will automatically detect all I/O boards on the local network.

Identify - Identifies an I/O board by sounding its on-board sounder.

Remove - Deletes an I/O board.

The main display lists I/O boards on the network, displaying a green tick if communicating with it, the name of each board, the MAC address and IP address. Place a check in the box of the I/O boards that you wish to communicate with and Apply. Double clicking on a board will display its settings. The boards name can be amended, and any changes need to be applied to save.

A reservation should be made in the DHCP server, to ensure that the same IP address is issued each time, should the unit be reset. (Fixed IP) Consult your network administrator on detail of how to reserve IP addresses.

Each I/O board has four inputs and outputs; these can be edited in the relevant Inputs and Outputs tabs. By double clicking on the name this will allow you to change the name to give it meaning. e.g. Window contact.

The current settings of the I/O board are displayed in the table.

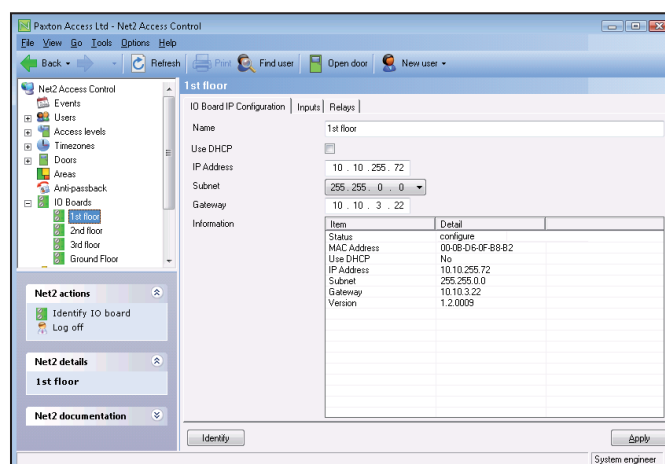

If you wish to connect to an I/O board which is located on the far side of a router it will not automatically be detected, you will need to enter the IP settings manually.

Add the board by clicking Manually add I/O board in the Net2 actions menu. Enter the MAC address printed on the board, followed by the IP address, Subnet and Gateway.